

# MX-COM, INC. MiXed Signal ICs

DATA BULLETIN

## MX019 Quad Digital Control Amplifier

### FEATURES

- 4 Digitally Controlled Amplifiers
- 15 Gain/Attenuation Steps
- 3 Amplifiers
  - ± 3dB Range in 0.43dB Steps
- 1 'Volume' Amplifier
  - ±14dB Range in 2dB Steps
- 8-Bit Serial Data Control
- Output Mute Function

### APPLICATIONS

- Gain Control Applications
  - Audio
  - Data
- Telecommunications, Radio, & Industrial Applications

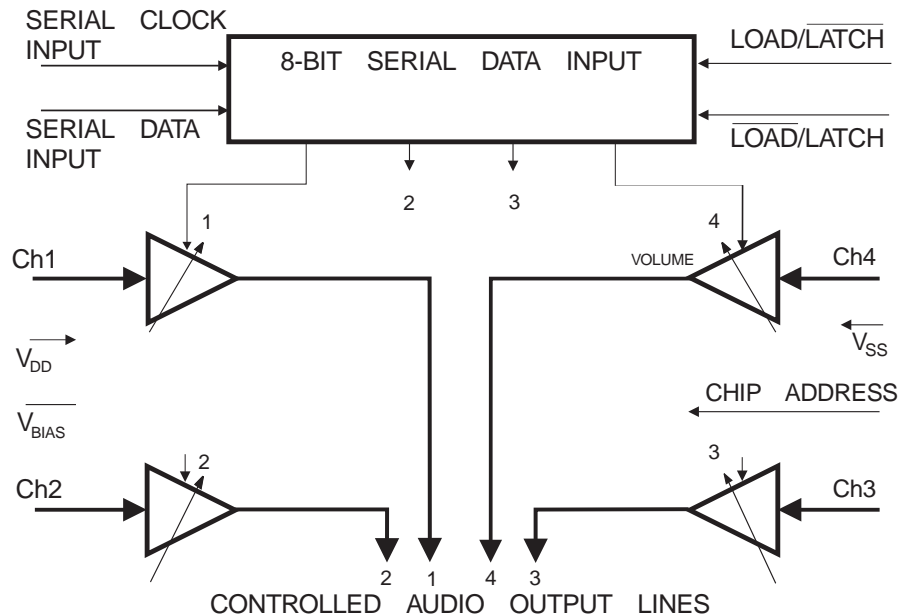

The MX019 Digitally Adjustable Amplifier Array replaces trimmer potentiometers and volume controls in Cellular, LMR, Telephony and Communication applications where voice or data signals need adjustment.

The MX019 is a single-chip LSI consisting of four digitally controlled amplifier stages, each with 15 distinct gain/attenuation steps. Control of each individual amplifier is by an 8-bit serial data stream. Three of the amplifier stages offer a  $\pm 3\text{dB}$  range in steps of 0.43dB, while the remaining amplifier offers a  $\pm 14\text{dB}$  range in steps of 2dB, and is suggested for volume control applications. Each amplifier includes a 16th 'Off' state which, when applied, mutes the output audio from that channel. This array uses a Chip Select input to select one of two MX019s in a system. The MX019 uses the host microprocessor to digitally control the set-up of all audio levels during development, production/calibration, and operation. Such applications include:

1. Control, adjustment, and set-up of communications equipment by an Intelligent ATE without manual intervention – eg. Deviation, Microphone and L/S Levels, RX Audio Level etc.
2. Automatic Dynamic Compensation of drift caused by variations in temperature, linearity, etc.
3. Fully automated servicing and re-alignment.

The MX019 is a low-power, single 5-volt CMOS device available in 24-pin TSSOP (MX019TN), 16-pin SOIC (MX019DW), 16-pin CDIP (MX019J) and 16-pin PDIP (MX019P) package versions.

# CONTENTS

| Section                             | Page     |
|-------------------------------------|----------|
| <b>1. Block Diagram</b>             | <b>3</b> |
| <b>2. Signal List</b>               | <b>4</b> |
| <b>3. External Components</b>       | <b>5</b> |
| <b>4. General Description</b>       | <b>5</b> |
| 4.1 Control Data and Timing         | 5        |
| 4.1.1 Data Loading                  | 5        |
| 4.1.2 Timing                        | 7        |
| <b>5. Application</b>               | <b>8</b> |
| <b>6. Performance Specification</b> | <b>8</b> |
| 6.1 Electrical Performance          | 8        |
| 6.1.1 Absolute Maximum Ratings      | 8        |
| 6.1.2 Operating Limits              | 8        |
| 6.1.3 Operating Characteristics     | 9        |
| 6.2 Packaging                       | 10       |

MX-COM, Inc. reserves the right to change specifications at any time and without notice.

# 1. Block Diagram

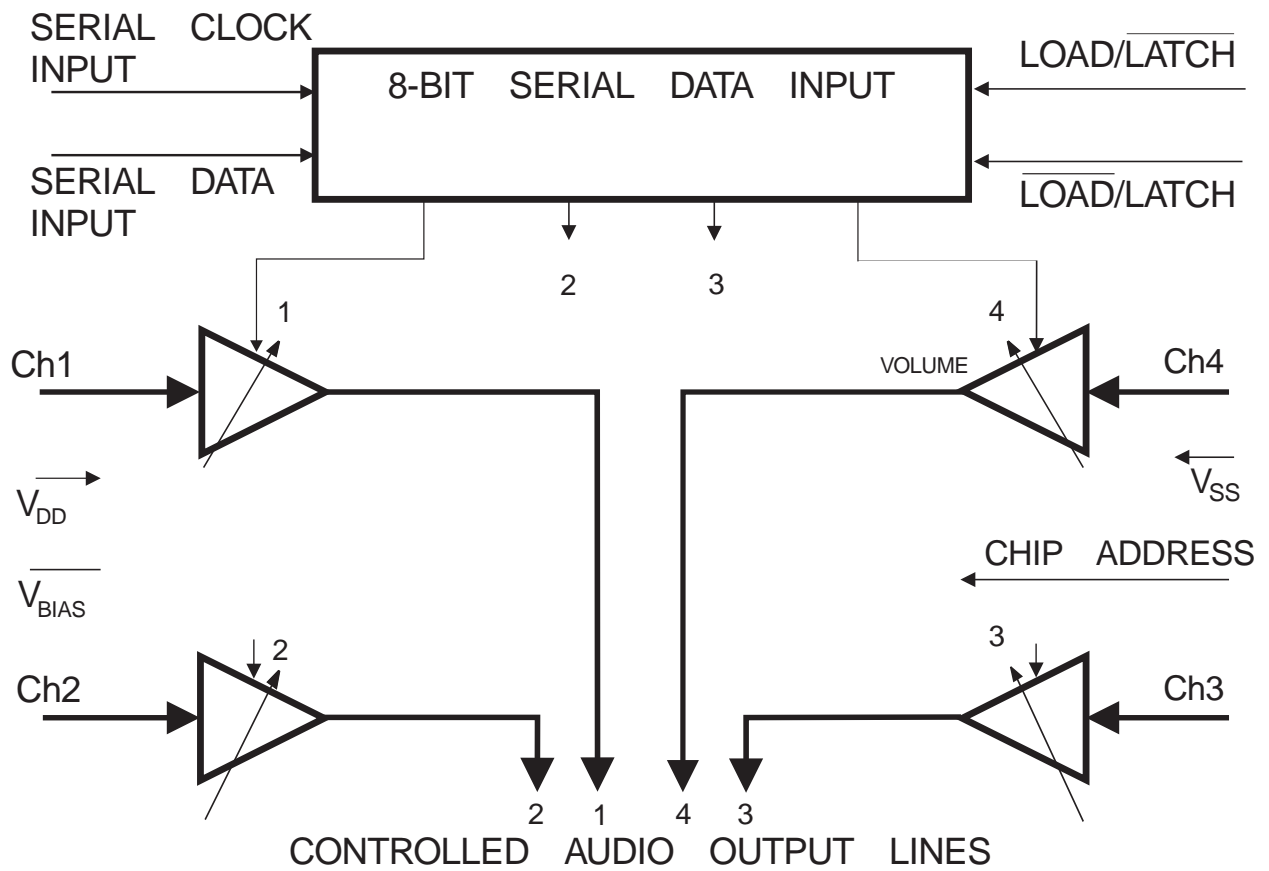

Figure 1: Device Block Diagram

## 2. Signal List

| Pin No.   |    | Name                            | Description  |
|-----------|----|---------------------------------|--|
| J/P<br>DW | TN |                                 |  |
| 1         | 1  | Serial Clock                    | This external clock pulse input is used to "clock in" the Control Data. See Figure 3. This input has an internal 1M $\Omega$ pullup resistor.  |
| 2         | 2  | Load/ $\overline{\text{Latch}}$ | This input governs the loading and execution of the control data. During serial data loading this input should be kept at a logical '0' to ensure that data rippling past the latches has no effect. When all 8 bits have been loaded, this input should be strobed '0 - 1 - 0' to latch the new data in. Data is executed on the falling edge of the strobe. If the $\overline{\text{Load/Latch}}$ input is used this pin should be left open circuit. This input has an internal 1M $\Omega$ pullup resistor.  |
| 3         | 4  | $\overline{\text{LOAD/LATCH}}$  | This inverted Load/ $\overline{\text{Latch}}$ input governs the loading and execution of control data. During serial data loading this input should be kept at a logical '1' to ensure that data rippling past the latches has no effect. When all 8 bits have been loaded, this input should be strobed '1' - '0' - '1' to latch the new data in. Data is executed on the rising edge of the strobe. If the Load/ $\overline{\text{Latch}}$ input is used this pin should be left open circuit. This input has an internal 1M $\Omega$ pulldown resistor. |
| 4         | 5  | Ch1 Input                       | <p style="text-align: center;"><b>Analog Inputs :</b></p> These individual amplifier inputs are self-biasing; AC input analog signals must be capacitively coupled to these pins, as shown in Figure 2.<br>Note that amplifiers Ch1 to Ch4 are 'inverting amplifiers.'   |
| 5         | 6  | Ch2 Input                       |  |
| 6         | 7  | Ch3 Input                       |  |
| 7         | 8  | Ch4 Input                       |  |
| 8         | 12 | V <sub>SS</sub>                 | Negative supply rail (GND).  |
| 9         | 13 | V <sub>BIAS</sub>               | The output of the on-chip bias circuitry, held at V <sub>DD</sub> /2. This pin should be decoupled to V <sub>SS</sub> as shown in Figure 2.  |
| 10        | 14 | Ch4 Output                      | <p style="text-align: center;"><b>Controlled Analog Outputs :</b></p> These are individual "Gain Controlled" amplifier outputs. Ch1 to Ch3 range from -3dB to +3dB in 0.43dB steps, Ch4 can be utilized as a volume control, ranging from -14dB to +14dB in 2.0dB steps. In the "OFF" mode there is no output from the selected amplifier.   |
| 11        | 17 | Ch3 Output                      |  |
| 12        | 18 | Ch2 Output                      |  |
| 13        | 19 | Ch1 Output                      |  |
| 14        | 20 | Chip Address                    | A logic input to select one of two MX019 ICs in a system (see Table 1). This input has an internal 1M $\Omega$ pulldown resistor.  |
| 15        | 23 | Control Data Input              | Operation of the 4 amplifier channels (Ch1 – Ch4) is controlled by the 8 bits of data entered serially at this pin. The data is entered (bit 7 to bit 0) on the rising edge of the external Serial Clock. The data format is described in Table 1, Table 2 and Figure 3. This input has an internal 1M $\Omega$ pullup resistor.   |
| 16        | 24 | V <sub>DD</sub>                 | Positive supply rail. A single +5V power supply is required.   |

### 3. External Components

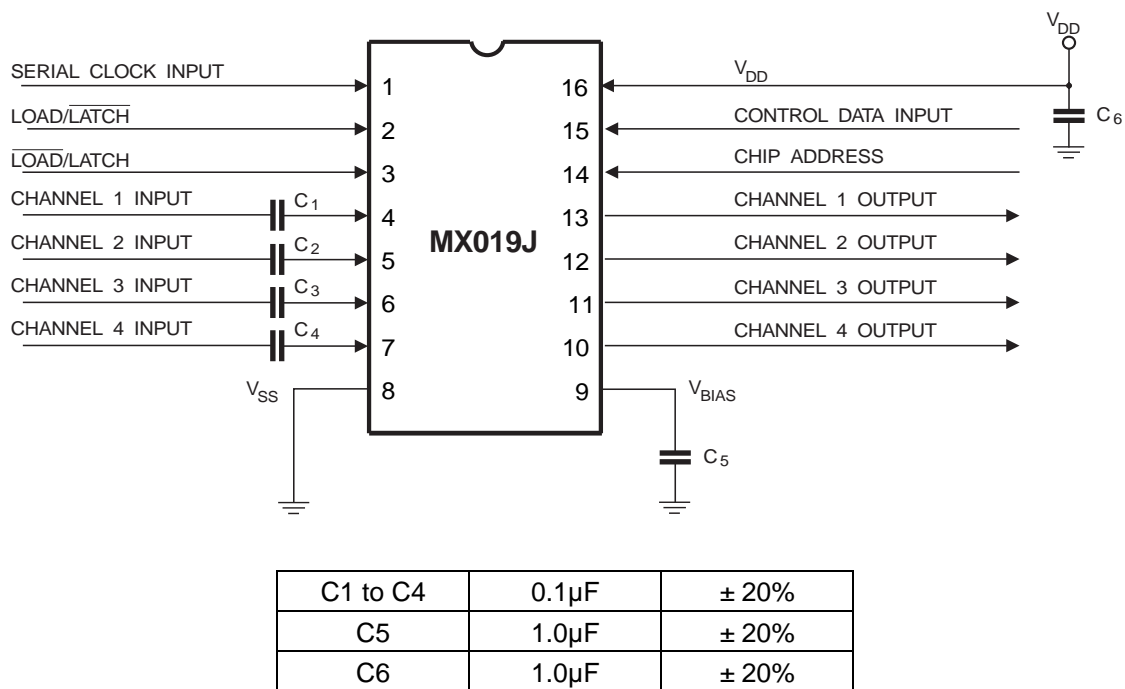

Figure 2: Recommended External Components

#### Notes:

1. Channel Amplifiers 1 to 4 are inverting amplifiers.
2. Analog input capacitors C1 to C4 are only required for AC input signals, DC input signals do not require these components.

## 4. General Description

### 4.1 Control Data and Timing

The gain of each amplifier block (Channel 1 to Channel 4) in the MX019 is set by a separate 8-bit data word (bit 7 to bit 0). This 8-bit word, consisting of 4 Address bits (bit 7 to bit 4) and 4 Gain Control bits (bit 3 to bit 0), is loaded to the Control Data Input in serial format using the external data clock.

#### 4.1.1 Data Loading

The 8-bit data word is loaded bit 7 first and bit 0 last.

Bit 7 must be a logic "1" to address the chip.

If bit 7 in the word is a logic "0" that 8-bit word will not be executed. The Chip Address input permits the use of two devices in a system by indicating to the chip what its address is, a "1" or a "0." Bit 6 in the address section of the control word is then used to select which device is being controlled. Figure 3 shows the timing information required to load and operate this device.

Data is loaded to the MX019 on the rising edge of the Serial Clock. Loaded data is executed on the falling (rising) edge of the Load/Latch ( $\overline{\text{Load/Latch}}$ ) pulse.

Table 1 shows the format of each 4-bit Address word, Table 2 shows the format of each Gain Control word with Figure 3 describing the data loading operation and timing.

| Bit 7<br>MSB | Bit 6 | Bit 5 | Bit 4<br>LSB | Channel<br>Address | Chip<br>Address | Chip<br>Number |
|--------------|-------|-------|--------------|--------------------|-----------------|----------------|
| 1            | 0     | 0     | 0            | 1                  | 0               | Chip 1         |
| 1            | 0     | 0     | 1            | 2                  | 0               |                |
| 1            | 0     | 1     | 0            | 3                  | 0               |                |
| 1            | 0     | 1     | 1            | 4                  | 0               |                |
| 1            | 1     | 0     | 0            | 1                  | 1               | Chip 2         |
| 1            | 1     | 0     | 1            | 2                  | 1               |                |
| 1            | 1     | 1     | 0            | 3                  | 1               |                |
| 1            | 1     | 1     | 1            | 4                  | 1               |                |

Table 1: Address Bits Format

| Bit 3<br>MSB | Bit2 | Bit 1 | Bit 0<br>LSB | Stage 1, 2, 3<br>(0.43dB) | Stage 4<br>(2.0dB) |
|--------------|------|-------|--------------|---------------------------|--------------------|
| 0            | 0    | 0     | 0            | OFF                       | OFF                |
| 0            | 0    | 0     | 1            | -3.0                      | -14.0dB            |
| 0            | 0    | 1     | 0            | -2.571                    | -12.0              |
| 0            | 0    | 1     | 1            | -2.143                    | -10.0              |
| 0            | 1    | 0     | 0            | -1.714                    | -8.0               |
| 0            | 1    | 0     | 1            | -1.286                    | -6.0               |
| 0            | 1    | 1     | 0            | -0.857                    | -4.0               |
| 0            | 1    | 1     | 1            | -0.428                    | -2.0               |
| 1            | 0    | 0     | 0            | 0                         | 0                  |
| 1            | 0    | 0     | 1            | 0.428                     | 2.0                |
| 1            | 0    | 1     | 0            | 0.857                     | 4.0                |
| 1            | 0    | 1     | 1            | 1.286                     | 6.0                |
| 1            | 1    | 0     | 0            | 1.714                     | 8.0                |
| 1            | 1    | 0     | 1            | 2.143                     | 10.0               |
| 1            | 1    | 1     | 0            | 2.571                     | 12.0               |
| 1            | 1    | 1     | 1            | 3.0                       | 14.0               |

Table 2: Gain Control Bits Format

## 4.1.2 Timing

| Timing (Figure 3)                             | Min. | Typ. | Max. | Units |
|---|------|------|------|-------|
| Serial Clock "High" Pulse Width ( $t_{PWH}$ ) | 250  |      |      | ns    |
| Serial Clock "Low" Pulse Width ( $t_{PWL}$ )  | 250  |      |      | ns    |
| Data Set-up Time ( $t_{DS}$ )                 | 150  |      |      | ns    |
| Data Hold Time ( $t_{DH}$ )                   | 50.0 |      |      | ns    |
| Load/Latch Pulse Width ( $t_{LLW}$ )          | 150  |      |      | ns    |
| Load/Latch Delay ( $t_{LLD}$ )                | 200  |      |      | ns    |
| Load/Latch Over ( $t_{LLO}$ )                 |      |      | 0.0  | ns    |
| Serial Data Clock Frequency                   |      |      | 2.0  | MHz   |

## SERIAL DATA CLOCK

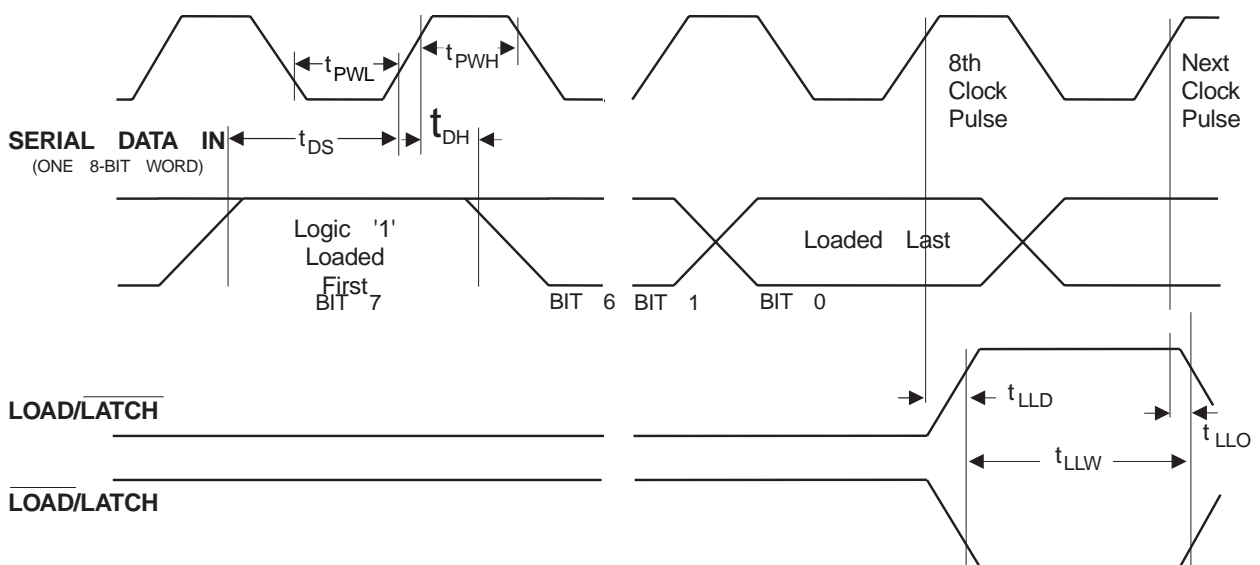

Figure 3: Serial Control Data Loading Diagram

## 5. Application

To avoid excess noise and instability you should take note of the following:

1. A noisy or badly regulated power supply can cause instability and/or variance of selected gains.
2. Care should be taken on the design and layout of the printed circuit board.
3. All external components (Figure 2) should be kept close to the MX019 package.
4. Inputs and outputs should be shielded wherever possible.
5. Tracks should be kept short.
6. Analog tracks should not run parallel to digital tracks.
7. A "Ground Plane" connected to  $V_{SS}$  will assist in eliminating external pick-up on the channel input and output pins.
8. Do not run high-level output tracks close to low-level input tracks.

## 6. Performance Specification

### 6.1 Electrical Performance

#### 6.1.1 Absolute Maximum Ratings

Exceeding these maximum ratings can result in damage to the device.

| General  | Min. | Max.             | Units                               |
|--|------|------------------|-------------------------------------|
| Supply Voltage                                   | -0.3 | 7.0              | V                                   |
| Input Voltage at any pin (ref $V_{SS} = 0V$ )    | -0.3 | $(V_{DD} + 0.3)$ | V                                   |
| Current  |      |                  |                                     |
| $V_{DD}$   |      | $\pm 30$         | mA                                  |
| $V_{SS}$   |      | $\pm 30$         | mA                                  |
| Any other pins                                   |      | $\pm 20$         | mA                                  |
| <b>J/P/DW Packages</b>                           |      |                  |                                     |
| Total Device Dissipation @ $T_{AMB} 25^{\circ}C$ |      | 800              | mW                                  |
| Derating above $25^{\circ}C$                     |      | 10               | mW/ $^{\circ}C$ above $25^{\circ}C$ |
| <b>TN Packages</b>                               |      |                  |                                     |
| Total Device Dissipation @ $T_{AMB} 25^{\circ}C$ |      | 500              | mW                                  |
| Derating above $25^{\circ}C$                     |      | 9                | mW/ $^{\circ}C$ above $25^{\circ}C$ |
| Operating Temperature                            | -40  | 85               | $^{\circ}C$                         |
| Storage Temperature                              | -55  | 125              | $^{\circ}C$                         |

#### 6.1.2 Operating Limits

Correct operation of the device outside these limits is not implied.

|                       | Min. | Typ. | Max. | Units       |
|-----------------------|------|------|------|-------------|
| $V_{DD}$              | 4.5  | 5.0  | 5.5  | V           |
| Operating Temperature | -40  |      | 85   | $^{\circ}C$ |



### 6.1.3 Operating Characteristics

For the following conditions unless otherwise specified:

$V_{DD} = 5.0V$ ,  $T_{AMB} = 25^{\circ}C$

Audio Level 0dB ref. = 775mV<sub>RMS</sub>, Amplifier Gain Set = 0dB

|                                     | Notes | Min.  | Typ.  | Max   | Units             |
|-------------------------------------|-------|-------|-------|-------|-------------------|
| <b>Static Values</b>                |       |       |       |       |                   |
| Supply Current                      |       |       | 1.5   |       | mA                |
| <b>Dynamic Values</b>               |       |       |       |       |                   |
| Control Functions                   |       |       |       |       |                   |
| Input Logic '1'                     |       | 3.5   |       |       | V                 |
| Input Logic '0'                     |       |       |       | 1.5   | V                 |
| Digital Input Impedances            |       | 0.5   | 1.0   |       | MΩ                |
| <b>Amplifier Stages (General)</b>   |       |       |       |       |                   |
| Bandwidth (-3dB)                    |       | 20.0  |       |       | kHz               |
| Output Impedance                    |       |       | 1.0   |       | kΩ                |
| Total Harmonic Distortion           | 1     |       | 0.35  | 0.5   | %                 |
| Output Noise Level (per stage)      | 2     |       | 180.0 | 400.0 | μV <sub>RMS</sub> |
| Onset of Clipping                   | 3     |       | 1.73  |       | V <sub>RMS</sub>  |
| Gain Variation                      | 4     |       |       | 0.1   | dB                |
| Interstage Isolation                |       |       | 60.0  |       | dB                |
| <b>“Trimmer” Stages (Ch1 – Ch3)</b> |       |       |       |       |                   |
| Gain                                |       | -3.0  |       | +3.0  | dB                |
| Gain per Step (15 in No.)           |       |       | 0.43  |       | dB                |
| Step Error                          |       |       |       | 0.2   | dB                |
| Input Impedance                     |       | 100.0 |       |       | kΩ                |
| <b>“Volume” Stage (Ch4)</b>         |       |       |       |       |                   |
| Gain                                |       | -14.0 |       | +14.0 | dB                |
| Gain per Step (15 in No.)           |       |       | 2.0   |       | dB                |
| Step Error                          |       |       |       | 0.4   | dB                |
| Input Impedance                     |       | 50.0  |       |       | kΩ                |

#### Operating Characteristics Notes:

1. Gain Set 0dB, Input Level 1kHz -3.0dB (549mVrms).
2. With an a.c short-circuit input, measured in a 30kHz bandwidth.
3. See Figure 4.
4. Over the temperature and supply voltage range.

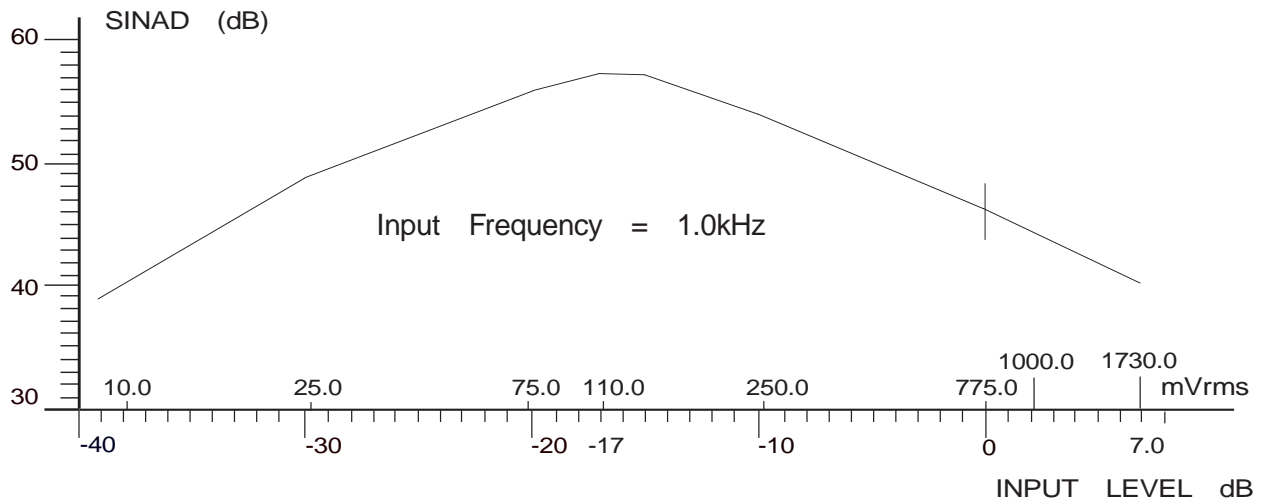

Figure 4: SINAD vs Input Level – Typical Values

### 6.2 Packaging

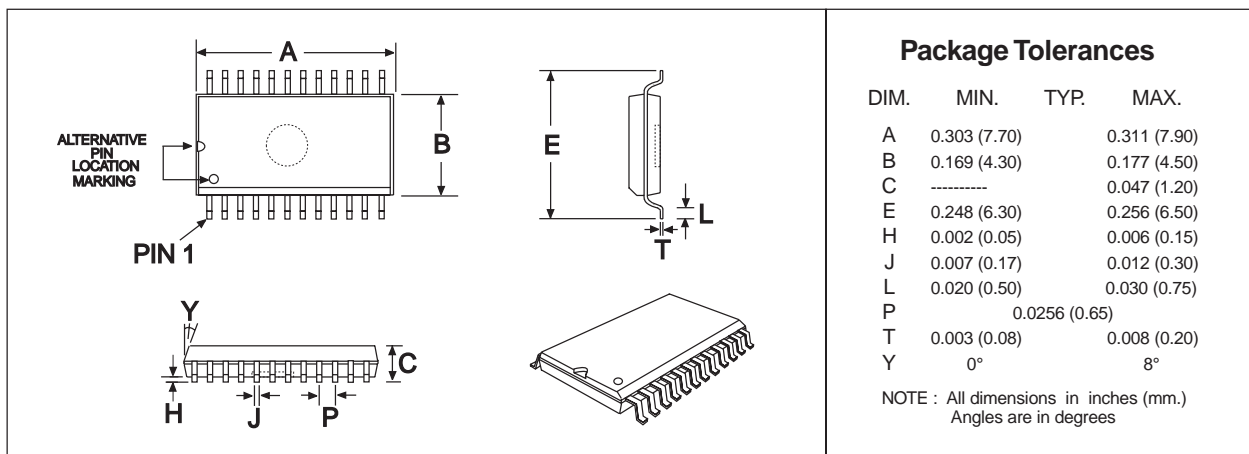

Figure 5: 24-pin TSSOP Mechanical Outline: Order as part no. MX019TN

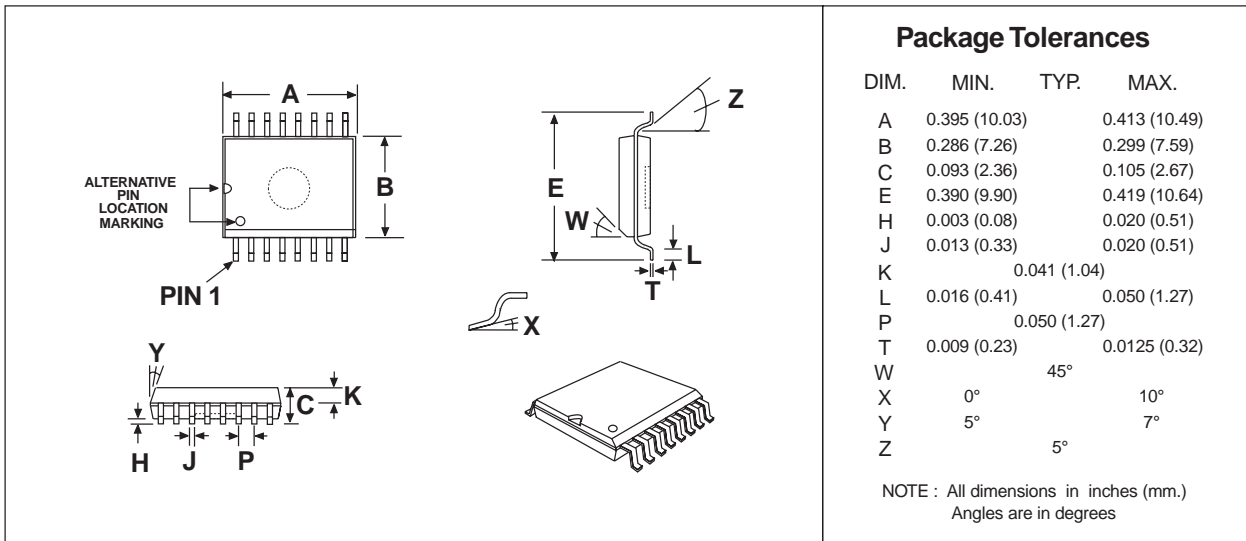

Figure 6: 16-pin SOIC Mechanical Outline: Order as part no. MX019DW

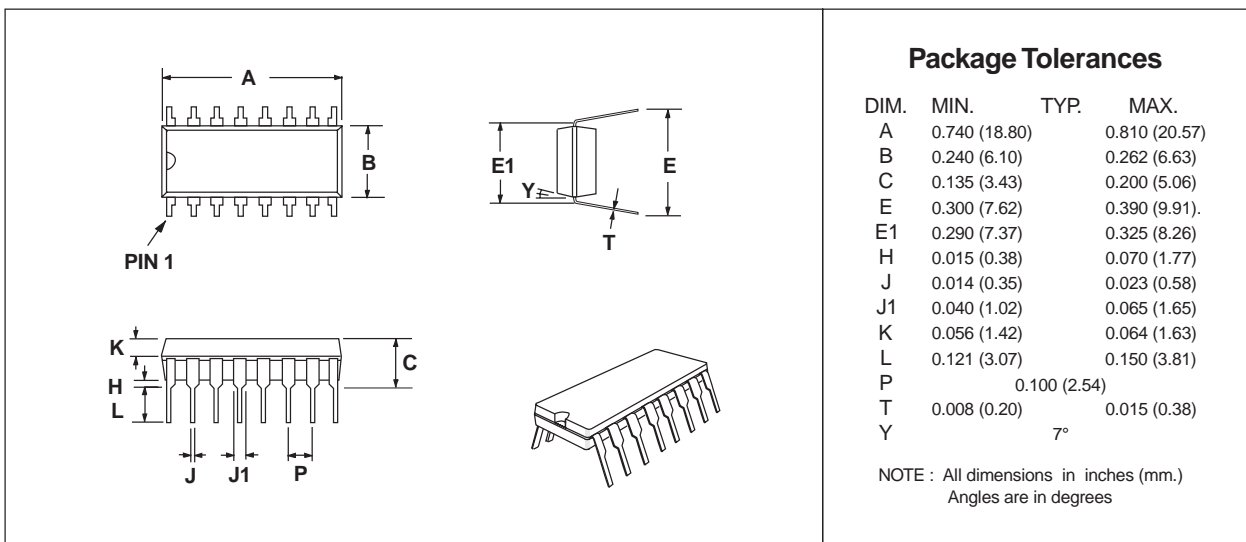

Figure 7: 16-pin PDIP Mechanical Outline: Order as part no. MX019P

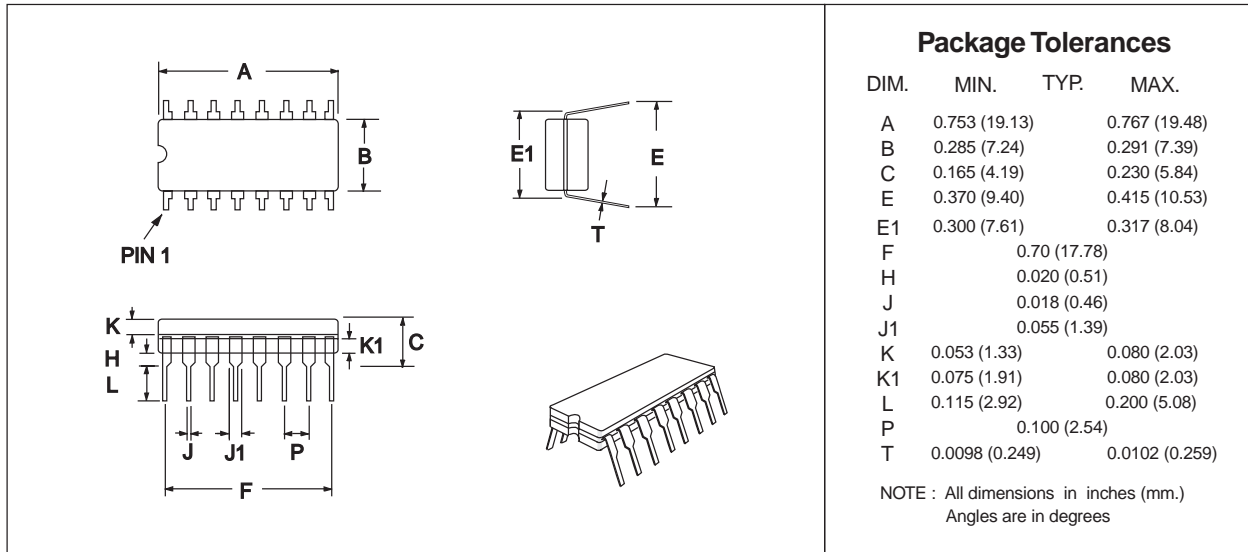

Figure 8: 16-pin CDIP Mechanical Outline: Order as part no. MX019J



**CML Microcircuits**

COMMUNICATION SEMICONDUCTORS

## CML Product Data

In the process of creating a more global image, the three standard product semiconductor companies of CML Microsystems Plc (*Consumer Microcircuits Limited (UK)*, *MX-COM, Inc (USA)* and *CML Microcircuits (Singapore) Pte Ltd*) have undergone name changes and, whilst maintaining their separate new names (*CML Microcircuits (UK) Ltd*, *CML Microcircuits (USA) Inc* and *CML Microcircuits (Singapore) Pte Ltd*), now operate under the single title **CML Microcircuits**.

These companies are all 100% owned operating companies of the CML Microsystems Plc Group and these changes are purely changes of name and do not change any underlying legal entities and hence will have no effect on any agreements or contacts currently in force.

### CML Microcircuits Product Prefix Codes

Until the latter part of 1996, the differentiator between products manufactured and sold from MXCOM, Inc. and Consumer Microcircuits Limited were denoted by the prefixes MX and FX respectively. These products use the same silicon etc. and today still carry the same prefixes. In the latter part of 1996, both companies adopted the common prefix: CMX.

This notification is relevant product information to which it is attached.

### CML Microcircuits (USA) [formerly MX-COM, Inc.] Product Textual Marking

On CML Microcircuits (USA) products, the '**MX-COM**' textual logo is being replaced by a '**CML**' textual logo.

Company contact information is as below:



**CML Microcircuits  
(UK) Ltd**

COMMUNICATION SEMICONDUCTORS

Oval Park, Langford, Maldon,  
Essex, CM9 6WG, England  
Tel: +44 (0)1621 875500  
Fax: +44 (0)1621 875600  
uk.sales@cmlmicro.com  
www.cmlmicro.com



**CML Microcircuits  
(USA) Inc.**

COMMUNICATION SEMICONDUCTORS

4800 Bethania Station Road,  
Winston-Salem, NC 27105, USA  
Tel: +1 336 744 5050,  
0800 638 5577  
Fax: +1 336 744 5054  
us.sales@cmlmicro.com  
www.cmlmicro.com



**CML Microcircuits  
(Singapore) Pte Ltd**

COMMUNICATION SEMICONDUCTORS

No 2 Kallang Pudding Road, 09-05/  
06 Mactech Industrial Building,  
Singapore 349307  
Tel: +65 7450426  
Fax: +65 7452917  
sg.sales@cmlmicro.com  
www.cmlmicro.com